

PARTS AND FEATURES

SPECIAL FEATURES

1 DETERGENT DISPENSER DRAWER

This three-compartment drawer provides separate dispensers for prewash and main wash detergent, and liquid fabric softener.

2 CONTROL PANEL WITH LED DISPLAY

Simple electronic controls are user-friendly. The LED display indicates cycle options and cycle time during operation.

3 LARGE-CAPACITY STAINLESS STEEL DRUM

The large capacity stainless steel drum offers extreme durability and is tilted to improve efficiency and allow easier access for large items.

NOTE: No matter how large the article, there must still be room for the clothes to tumble.

4 DIRECT-DRIVE MOTOR

Direct-drive motor eliminates the belt and pulleys found on most washers to provide improved performance and reliability while increasing energy efficiency.

5 DRAIN ACCESS PANEL

Provides access to the drain line and drain pump filter.

6 EASY-ACCESS DOOR

Extra-large door locks during operation and features a delay to prevent the door from being opened until the washer interior has cooled and the water level has lowered.

7 LEVELING FEET

Four leveling feet (two in the front and two in the back) adjust to improve washer stability on uneven floors.

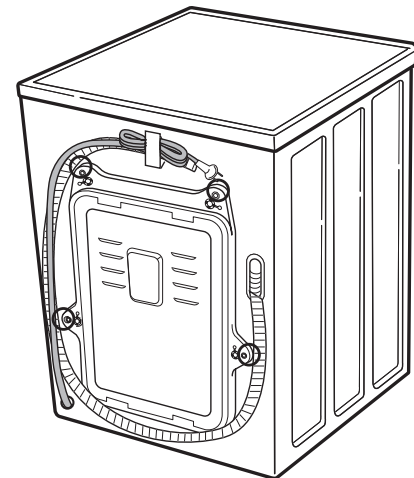
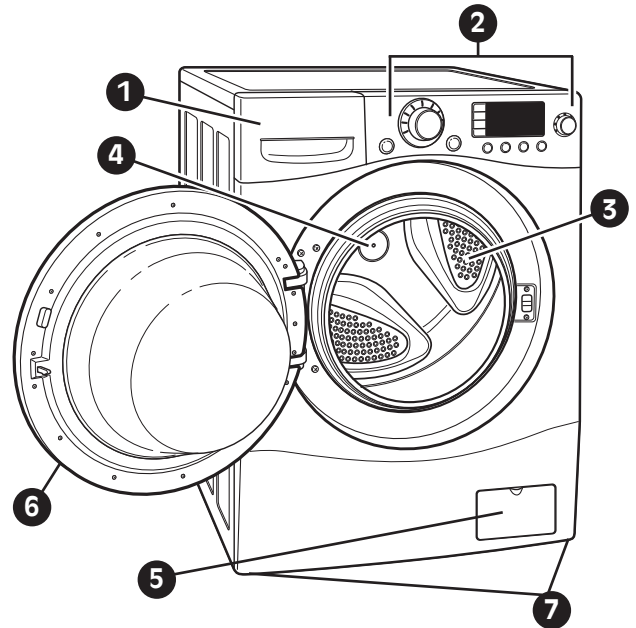

Rear of Washer

Included Accessories

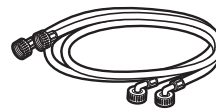

Hot and Cold Water Hoses

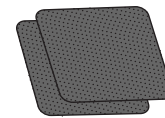

Non-skid pads

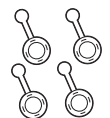

Caps (4)
(for covering shipping bolt holes)

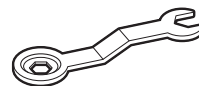

Wrench
(for removing shipping bolts and adjusting leveling feet)



Tie Strap
(for securing drain hose)

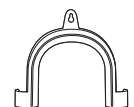

Elbow Bracket
(for securing drain hose)

INSTALLATION INSTRUCTIONS

CHOOSE THE PROPER LOCATION

⚠ WARNING

- **Washer is heavy! Two or more people are required when moving and unpacking the washer.** Failure to do so can result in back or other injury.
- **Store and install the washer where it will not be exposed to temperatures below freezing or exposed to outdoor weather conditions.** Failure to follow this warning can cause serious injury, fire, electrical shock, or death.
- **Properly ground washer to conform with all governing codes and ordinances.** Failure to follow this warning can cause serious injury, fire, electrical shock, or death.
- **To reduce the risk of electric shock, do not install the washer in humid spaces.** Failure to follow this warning can cause serious injury, fire, electrical shock, or death.

- **Do not remove ground prong. Do not use an adapter or extension cord. Plug into a grounded 3-prong outlet.** Failure to follow this warning can cause serious injury, fire, electrical shock, or death.

Power Outlet

- The power outlet must be within 60 in. (1.5 m) of either side of the washer.
- The appliance and outlet must be positioned so that the plug is easily accessible.
- Do not overload the outlet with more than one appliance.
- The outlet must be grounded in accordance with current wiring codes and regulations.
- Time-delay fuse or circuit breaker is recommended.

NOTE: It is the personal responsibility and obligation of the product owner to have a proper outlet installed by a qualified electrician.

CLEARANCES

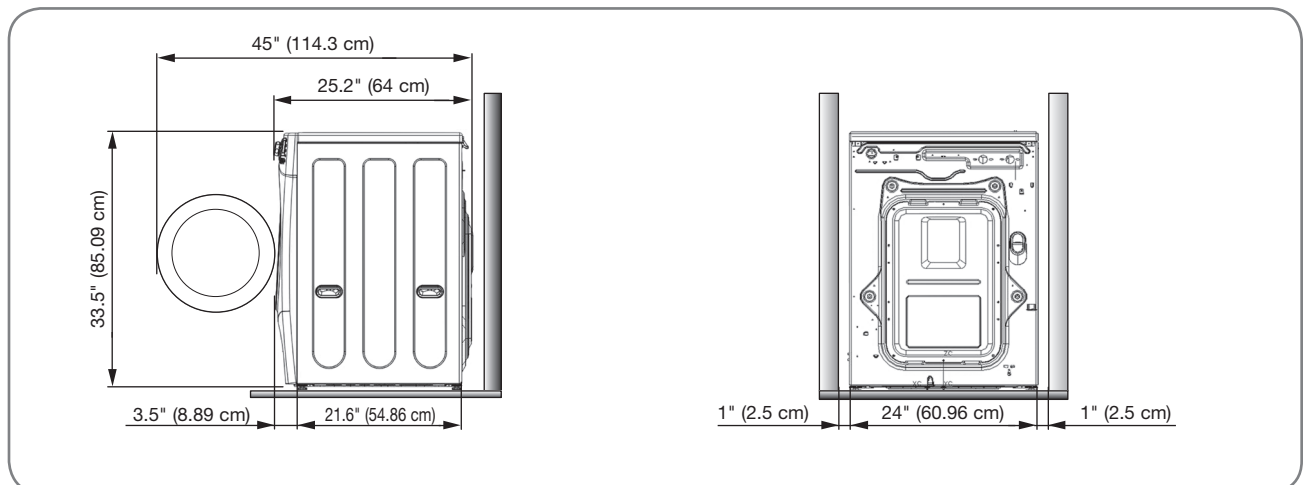

To ensure sufficient clearance for water lines and airflow, allow minimum clearances of at least 1 in. (2.5 cm) at the sides and 4 in. (10 cm) behind the unit. Be sure to allow for wall, door, or floor moldings that may increase the required clearances.

Allow at least 19.8 in. (50.3 cm) in front of the washer to open the door.

INSTALLATION INSTRUCTIONS

FLOORING

- To minimize noise and vibration, the washer **MUST** be installed on a solidly constructed floor. See the NOTE at right.
- Allowable slope under the entire washer is 1° maximum.
- Carpeting and soft tile surfaces are not recommended.
- Never install the washer on a platform or weakly supported structure. Use only an approved accessory pedestal as described below.

NOTE: Please note that the floor must be strong and rigid enough to support the weight of the washer when fully loaded, without flexing or bouncing. If your floor has too much flex in it, you may need to reinforce it to make it more rigid. A floor that is adequate for a top-loading washer may not be rigid enough for a front-loading washer due to the difference in the spin speed and direction. If the floor is not solid, your washer may vibrate and you may hear and feel the vibration throughout your house.

NOTE: Before installing the washer, make sure the floor is clean, dry and free of dust, dirt, water and oils so the washer feet can not slide easily. Leveling feet that can move or slide on the floor can contribute to excess vibration and noise due to poor contact with the floor.

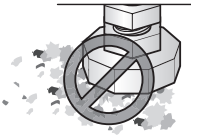

INSTALLATION INSTRUCTIONS

UNPACKING

If you must lay the washer down to remove the base packaging materials, always lay it carefully on its side. Do NOT lay the washer on its front or back.

IMPORTANT: To prevent internal damage during transport, the washer is equipped with 4 shipping bolts and plastic retainers. These bolts and retainers **MUST** be removed before operating the washer.

- Failure to remove shipping bolts and retainers may cause severe vibration and noise, which can lead to permanent damage to the washer. The cord is secured to the back of the washer with a shipping bolt to help prevent operation with shipping bolts in place.

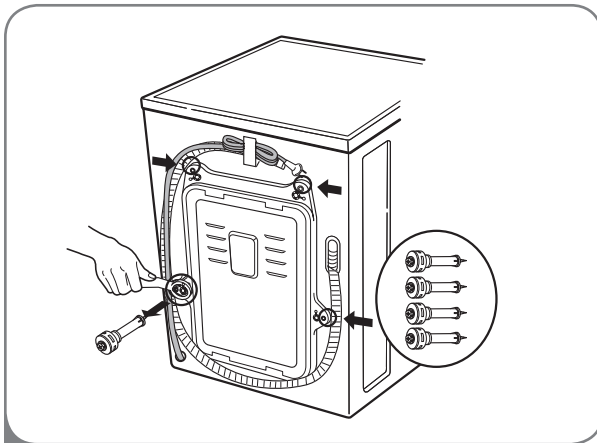
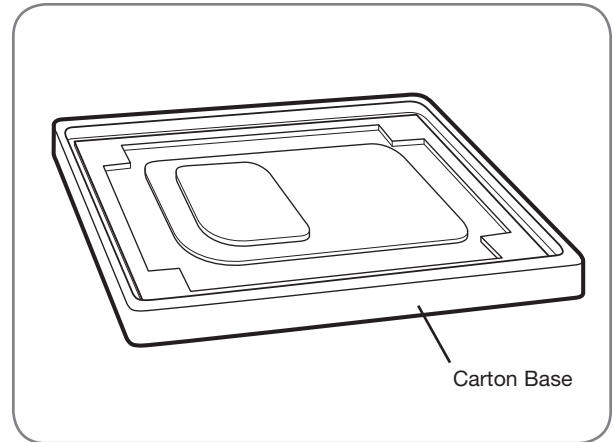

- 1 Starting with the bottom 2 shipping bolts, use the included wrench to remove the 4 shipping bolts by turning them counterclockwise.

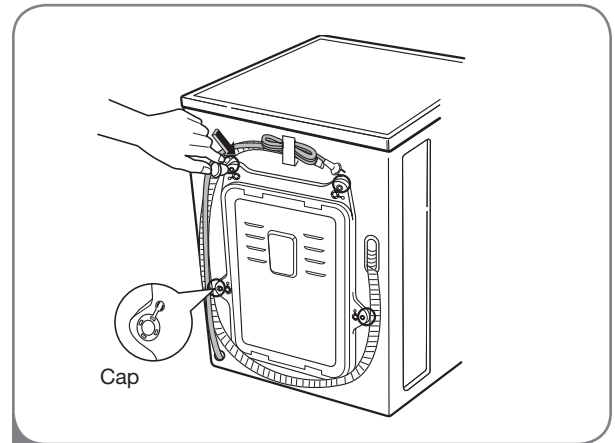

- 2 Remove the retainers by turning them slightly while pulling. Rotate and press the hole caps into the shipping bolt holes.

NOTE: Save the bolts and retainers for future use. To prevent damage to internal components, the shipping bolts and retainers must be installed when transporting the washer.

INSTALLATION INSTRUCTIONS

CONNECTING THE WATER LINES

- **IMPORTANT:** Use new hoses when installing the washer. Do NOT reuse old hoses.
- **IMPORTANT:** Use ONLY the inlet hoses provided by LG with this laundry product. Aftermarket hoses are not guaranteed to fit or function correctly. Other hoses may not tighten correctly and could cause leaks. Subsequent damage to product or property will not be covered under the terms of LG's warranty.
- Water supply pressure must be between 14.5 PSI and 116 PSI (100~800 kPa). If the water supply pressure is more than 116 PSI, a pressure reducing valve must be installed.
- Periodically check the hose for cracks, leaks, and wear, and replace the hose if necessary.
- Make sure that the water lines are not stretched, pinched, crushed, or kinked.
- The washer should never be installed or stored in a location subject to freezing temperatures. Damage to the water lines and internal mechanisms of the washer can result. If the washer was exposed to freezing temperatures prior to installation, allow it to stand at room temperature for several hours before use.

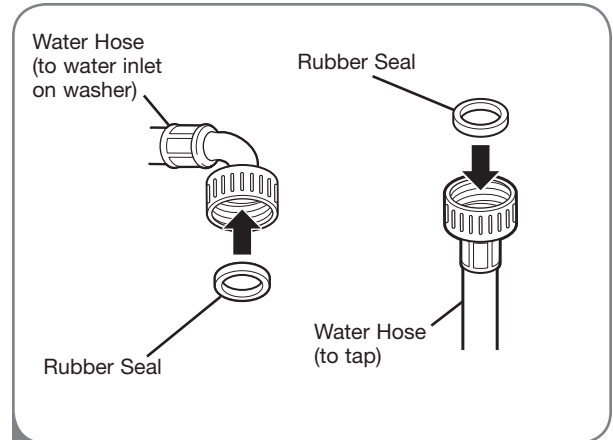

- 1 Insert a rubber seal into the threaded fittings on each hose.

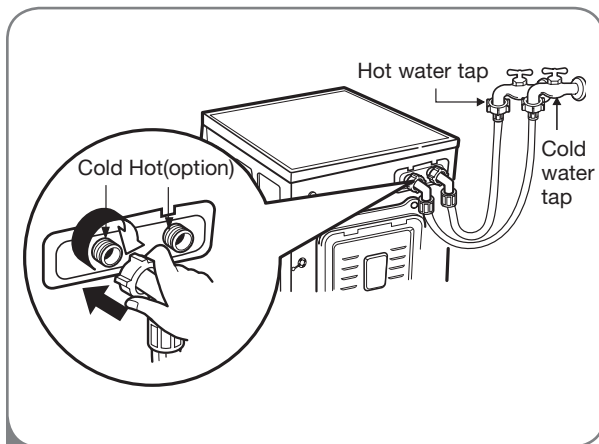

- 2 **NOTE:** Do not cross-thread the hose fittings. Attach the hot water line to the red hot water inlet on the back of the washer. Attach the cold water line to the blue cold water inlet on the back of the washer. Tighten the fittings securely.

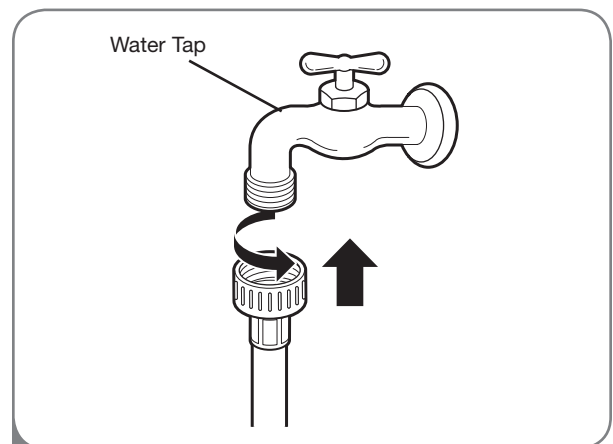

- 3 Attach the hot water line to the hot water tap. Attach the cold water line to the cold water tap.

Tighten the fittings securely. Open the water taps fully to check for leaks.

INSTALLATION INSTRUCTIONS

CONNECTING THE DRAIN LINE

- The drain hose should always be properly secured. Failure to properly secure the drain hose can result in flooding and property damage.
- Do not install the end of the drain hose higher than 96 in. (244.8 cm) above the bottom of the washer.
- The drain must be installed in accordance with any applicable local codes and regulations.
- Make sure that the water lines are not stretched, pinched, crushed, or kinked.

NOTE: If the drain hose is extended more than 4 inches beyond the end of the elbow bracket, mold, or microorganisms could spread to the inside of the washer.

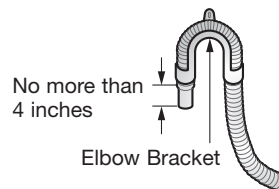

Option 1: Standpipe

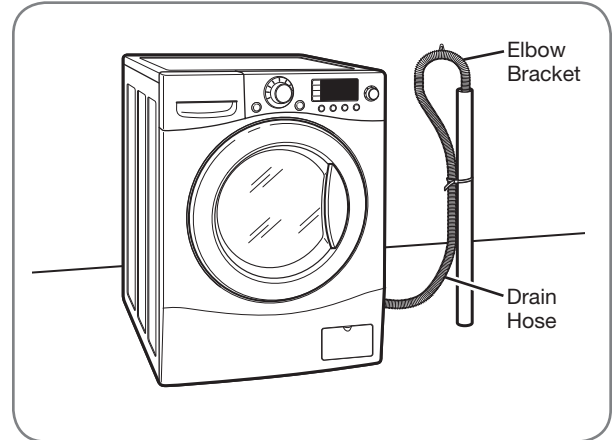

Clip the end of the hose into the elbow bracket. Insert the end of the drain hose into a standpipe. Use tie strap to secure the drain hose in place.

NOTE: Total height of the hose end should not exceed 96 in. (244.8 cm) from the bottom of the washer.

Option 2: Laundry Tub

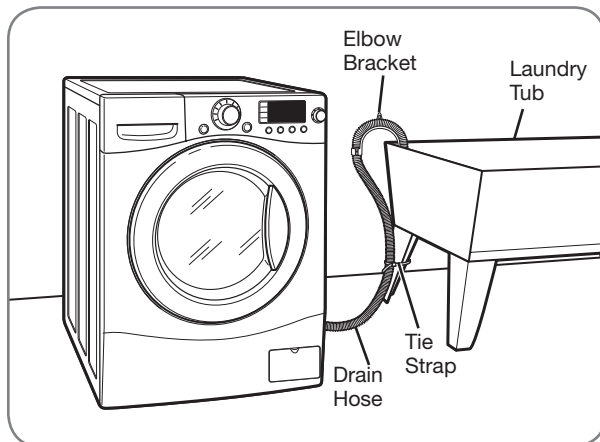

Clip the end of the hose into the elbow bracket. Hang the end of the drain hose over the side of the laundry tub. Use tie strap to secure the drain hose in place.

NOTE: Total height of the hose end should not exceed 96 in. (244.8 cm) from the bottom of the washer.

INSTALLATION INSTRUCTIONS

LEVELING THE WASHER

The drum of your new washer spins at very high speeds, up to 1,300 RPM. To minimize vibration, noise, and unwanted movement, the floor must be a perfectly level, solid surface.

NOTE: Adjust the leveling feet only as far as necessary to level the washer. Extending the leveling feet more than necessary can cause the washer to vibrate.

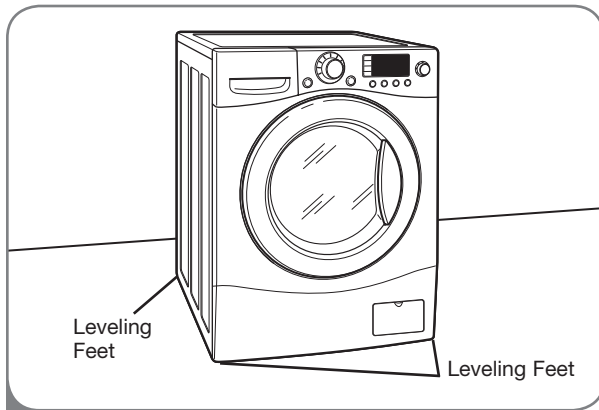

- 1 Position the washer in the final location, taking special care to not pinch, strain, or crush the water and drain lines. Place a level across the top of the washer.

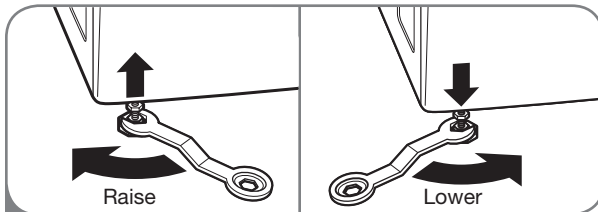

- 2 Loosen the locknuts on all 4 leveling feet until you can turn the feet with the included wrench. Turn clockwise to raise the washer or counterclockwise to lower it.

- All four leveling feet must rest solidly on the floor. Rock the washer gently from corner to corner to make sure that the washer does not rock.

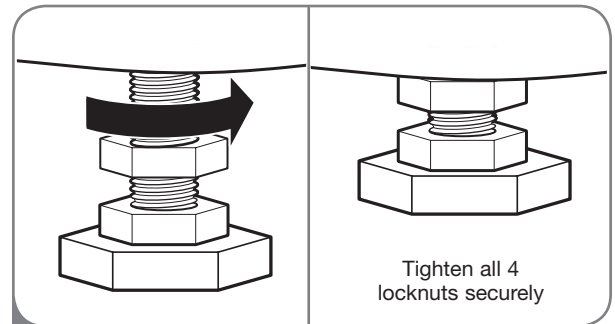

- 3 Once the washer is level from side to side and front to back, tighten all locknuts securely. Make sure that all 4 leveling feet are in firm contact with the floor.

NOTE: To make sure that the washer is properly level, run the washer with a test load: place approximately 6 pounds of laundry in the machine. Then, press POWER, press RINSE+SPIN, and then press the START/PAUSE button. (See the following sections for additional information on cycle selection and operation.)

Verify that the washer does not rock or vibrate excessively during the spin cycle.

If the washer vibrates or shakes, adjust the leveling feet until the washer is stable and retest.

INSTALLATION OF NON-SKID PADS (OPTIONAL)

Some floor surfaces are too slippery to prevent the washer from moving on the floor during heavily unbalanced loads. While it is normal for an occasional load to be out of balance, excess noise and vibration can result from the washer moving out of position. If these conditions are encountered, follow the instructions below for installation of the non-skid pads. These pads will help prevent the washer from moving during heavy out of balance conditions thereby reducing noise and vibration.

• Non-skid pads

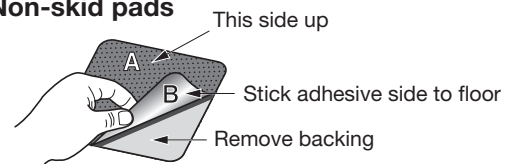

- * Place the pads under both front feet.

